

# SAFETY ISSUES, ARCING AND FUSING IN PV ARRAYS

Edward D Spooner<sup>1</sup>, Nigel Wilmot<sup>2</sup>

<sup>1</sup>Senior Lecturer

The University of New South Wales, Australia

[e.spooner@unsw.edu.au](mailto:e.spooner@unsw.edu.au)

<sup>2</sup>Research Institute for Sustainable Energy (RISE)

Murdoch University

Murdoch WA 6150

[nwilmot@rise.murdoch.edu.au](mailto:nwilmot@rise.murdoch.edu.au)

## ABSTRACT

The PV industry has been growing rapidly for many years and we are now seeing many new manufacturers coming on line. In more recent years there has been an emphasis on grid connected systems with government subsidy schemes, feed in tariffs and climate change driving industry growth. We have seen inverter manufacturers driving the PV array voltages up to 800 and 1000V d.c. for reasons of efficiency and cost reduction.

At the same time the industry has now had products out in the field for an extended period and we are seeing the affects of aging of modules, connectors and wiring system. All of these affects combined are leading to an increase in faults developing in systems. The high d.c. voltages lead to significant stress on insulation systems and the possibility of arcing faults developing. Safety issues for d.c. systems are much more significant than for ac systems because of arcing and corrosion issues that can develop.

Fusing is also a very important issue and difficult to craft accurately in PV system so that adequate protection is provided.

This paper explores the range of safety issues being faced by the industry and explores the response in terms of module and safety standards and new devices to improve array safety.

## INTRODUCTION

The PV industry has been growing rapidly for many years and we are now seeing many new manufacturers of modules, connectors inverters and associated equipment coming on line. In more recent years there has been an emphasis on grid connected systems with government subsidy schemes, feed in tariffs and climate change driving industry growth. We have seen inverter manufacturers driving the PV array voltages up to 800 and 1000V d.c. for reasons of efficiency and cost reduction.

At the same time the industry has now had a range of products out in the field for an extended period and we are seeing the affects of aging of modules, connectors and wiring systems. All of these affects combined are leading to an increase in faults developing in systems.

This paper explores the range of faults that can occur within a PV array, the characteristics of those faults and then looks at issues of protection and standards.

## **PV ARRAYS ARE UNIQUE**

Before proceeding further it is important to point out that PV arrays have quite unique characteristics which are generally different to many other electrical supply systems.

- They often have multiple series / parallel connected sources like some battery systems.
- Unlike battery systems they are current limited.
- They are d.c systems and so their design and protection are different to a.c. systems.
- They are now being applied at relatively high d.c. voltages.
- Array distributed over a large area, not enclosed in an electrical equipment enclosure.
- Some systems are connected to batteries.
- Some systems are connected to the grid via transformerless inverters.

All of these issues make design and protection of PV arrays challenging.

It is important also to note that PV arrays are by their very nature exposed to the elements, to wind, rain, hail, lightning, vibration, thermal cycling and UV exposure.

## **PV ARRAY ELECTRICAL FAULTS**

PV array faults can be categorized into:

- Short circuits
  - Earth fault
  - Positive to negative fault
  - Junction box fault
- Bad joints or hot spots which lead to overheating which lead to circuit interruption.
  - Module hot spots
  - Junction box connections
  - Module connectors
  - Combiner box connections

This is by no means an exhaustive list but it does cover the main problem areas.

### **Short circuits**

Short circuits arise primarily from failure of insulation or of course through poor workmanship. Insulation failure may occur through deterioration of insulation due to mechanical failure due to aging, vibration, wear, ultra-violet exposure or exposure to over-voltages (eg lightning). Short circuits may also result from the propagation of another fault such as an arcing fault causing damage to insulation.

A module junction box short circuit may result from insulation failure or through failure of a bypass diode.

Short circuits such as failure of insulation to a PV module frame may result in electric shock if the frame is not adequately earthed or a d.c. arc may result if the frame is earthed and the short circuit is not a low resistance contact. The ability for an arc to form depends on the available d.c. voltage and current and the circuit configuration.

Positive to negative short circuit faults may arise in areas where the two conductors are in close proximity such as in combiner boxes. A positive to negative fault generally results in catastrophic failure because of the high probability of an arc forming and because the whole array voltage and current is potentially available to feed the fault.

A module junction box short circuit within a single string where the individual module open circuit voltage is low may only lead to decreased array output but in an array with two or more strings in parallel it may lead to high reverse currents flowing in the faulted string which may lead to either string wiring failure or module failure if not prevented.

### **Bad joints or hot spots**

The main issue with bad joints is that this may lead through overheating or through fracture to an interruption of current in a d.c. circuit and a resulting arc. This is exacerbated by the relatively common use of high d.c. voltages in PV arrays.

Bad joints may occur in:

- modules due to poor quality control in manufacturing,
- junction boxes due to poor workmanship or through thermal cycling over many years of operation.
- Array wiring due to corrosion exacerbated by ingress of water into conductors.
- plug in connectors due to poor design, poor manufacturing, or through the use of mismatched connectors from different manufacturers.

### **In Modules**

Bad joints may occur within modules due to poor quality control in manufacture. If a failure occurs within a module under normal forward conduction an arc will not usually result if bypass diodes are fitted and operational. (Note that diodes are generally not considered to be a valid form of protection because they are a semiconductor and prone to failure.) If bypass diodes are not fitted or have failed then a series arc is possible in systems where the voltage is greater than 28V. Arcs may also occur in modules with bad joints under reverse current conditions if overcurrent protection is not adequate.

It is extremely important that modules for use in arrays with voltages greater than 50V be qualified to the most stringent safety standards available and that the manufacturers have quality control procedures in place to assure maintenance of high quality output.

### **In Array Wiring**

Bad joints may occur at any of the many series connections within an array. Once a bad joint develops it may lead to overheating or fracture of the joint and this may lead to the establishment of a d.c. arc.

### D.C. arcs in arrays

The severity of a d.c. arc in a pv array depends on a number of factors. This section explores a number of situations in grid connected PV systems where there is no battery present and voltages above 120V are usually involved. Arcs are also possible in stand alone PV systems where the voltages are much lower. A d.c. arc in air is possible at voltages from 28V and above. The length of the arc which may develop increases with increasing voltage and current availability.

It must be remembered that d.c. arcs burn at 3000°C plus. The temperature is related to the energy available and to the thermal characteristics of the assembly involved. (eg How well the arc is enclosed.) A temperature of 3000°C is quite capable of melting or burning circuit insulation, conductors and even glass, silicon and steel.

The result of an arc if it burns for any extended period can be a fire produced either through the direct radiation produced by the arc or by molten conductors, silicon or glass falling from the array and catching fire to adjacent material.

In current limited ac systems arcs are possible but the arc length is generally considerably shorter because the arc cools and may extinguish as the current passes through zero during the normal supply cycle. For d.c. however the current remains relatively constant and does not go through zero and so the arc is more readily maintained over relatively large gaps. Characteristics of d.c. arc voltage and current for various arc gaps are shown in fig. 1. The arc voltage and current which will be present for a particular gap length will depend on the supply characteristics and source resistance.

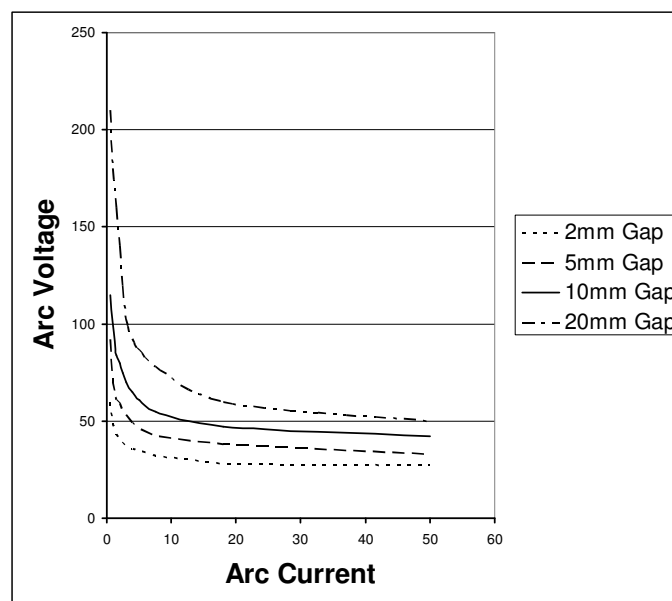

Fig. 1: Characteristics of d.c. arc voltage and current  
(Data extracted from “arcadvisor.com”)

In the case of a PV array consisting of one string connected to a maximum power point tracking (MPPT) inverter, the source characteristics of the single string with a series arc of varying lengths is shown in fig. 2.

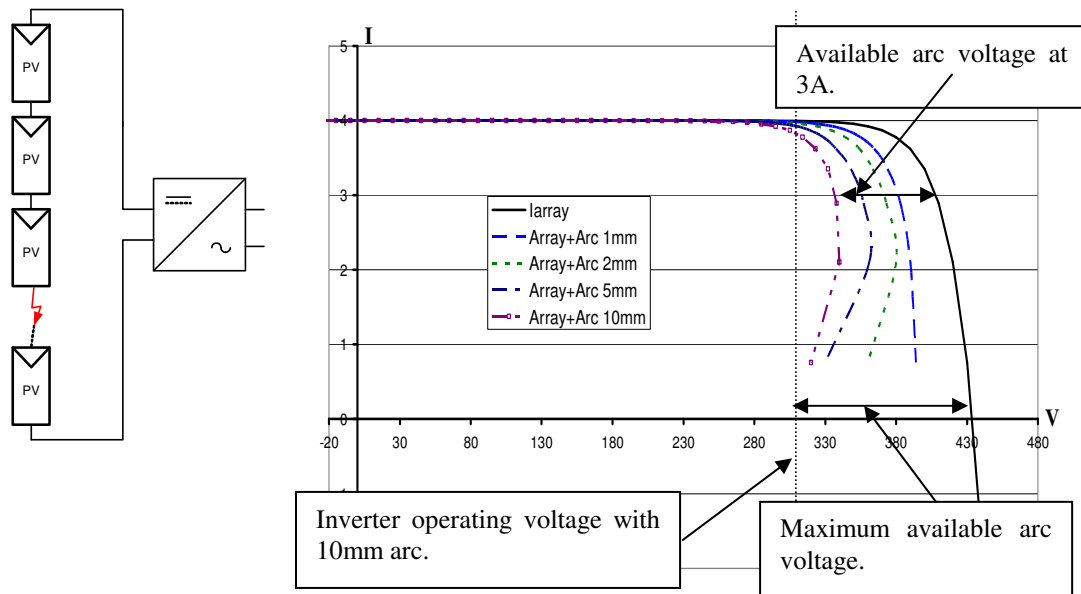

Fig. 2: IV characteristics of single PV string with and without a series arc.

( 20 modules in series with  $I_{sc} = 4A.$ )

Before the arc develops the inverter would normally be operating at the MPPT of the array. When the arc is struck the inverter will continue to operate provided the voltage it sees at its terminals is within the operating voltage window. The inverter will simply move down in operating voltage and find a new operating point. It is clear from these characteristics that a new operating point even with a 10mm arc can easily be established.

The arc voltage is the difference between the normal IV characteristic without the arc and the characteristic with the series arc at a selected operating current. At higher array voltages the operating window of the inverter is required to have a wider voltage range to cope with normal temperature variations within the array. This wide voltage window allows the inverter to continue to operate and to track the combined characteristic of the string and the arc.

If a PV array is made up of multiple parallel strings and an arc fault develops in the main array cable the situation is similar to the single string case except that the currents are much larger and so the damage can also be much greater. The situation is different in an array with multiple parallel strings where an arc develops in only one string. Fig. 3 shows the IV characteristics of the good strings. The inverter will tend to track the strings where there is no series arc. In this situation the maximum available arc voltage in the broken string is the difference between the inverter MPPT voltage (ie the operating voltage of the parallel connected array and the open circuit voltage of a single string as shown in the figure. It can easily be seen that the voltage available to an arc under these conditions is considerably less than in the single string case because of the difference in the operating point of the inverter. The open circuit voltage of this array however is only 430V and the voltage available to the arc is still approximately 50V which is enough to establish a stable arc. At higher array voltages the available arc voltage is also larger. If however the array voltage was reduced by a factor of two for

example, then an arc voltage greater than 28V would not be possible in a single broken string and an arc could not be established.

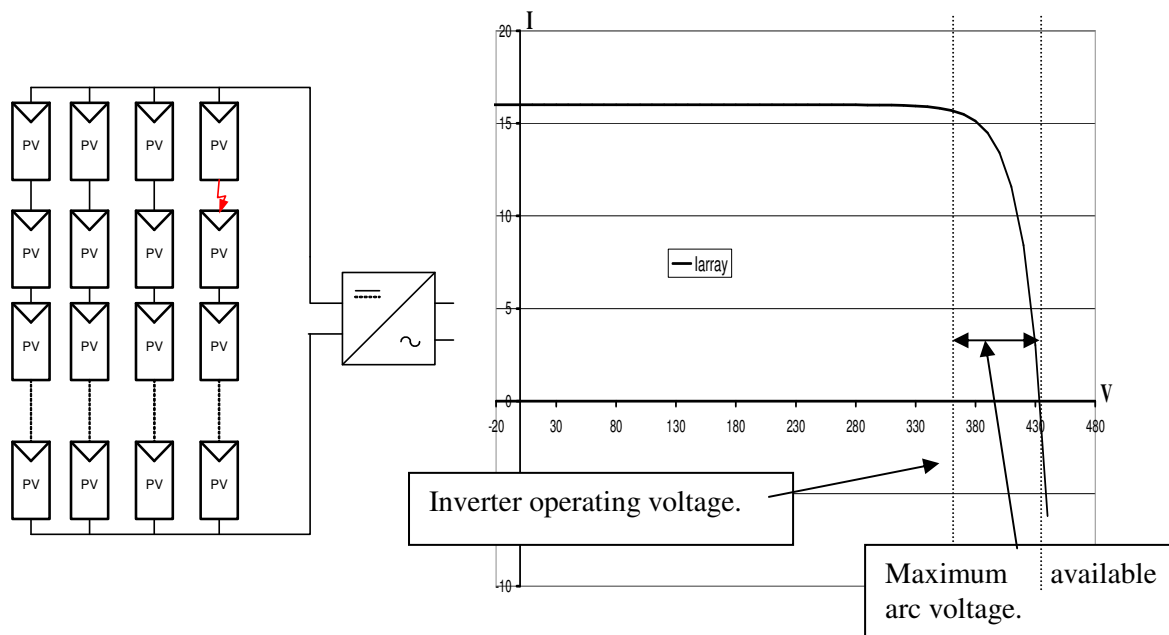

Fig. 3: IV Characteristics of 4 parallel connected strings.

## PROTECTION

### Arc Protection

Clearly d.c. arcs in pv arrays are an issue which needs to be addressed. The issue may be partly addressed by ensuring high quality components and workmanship but this only partly addresses the issue because all systems age eventually and unless a system of extensive maintenance is used eventually joints weaken and arcs may develop. In the US ac arc detectors are mandatory on all domestic dwellings in habitable areas to prevent fires. Unfortunately a d.c. equivalent arc detector is not yet available but is under consideration in a project by Underwriters Limited.

Detecting a d.c. arc in pv arrays requires detection of an arc signature. This has been accomplished in a research prototype system (H. Häberlin, 2007) but requires further testing and development to produce a commercial product. Discussions within the systems working group of IEC Technical Committee 82 "Photovoltaics" are considering the incorporation of a requirement for arc detection in PV systems when it becomes available.

The next question that needs addressing is what can be done once an arc develops? There are two main categories of arcs: series arcs due to a bad connection or a break in wiring and parallel arcs resulting from a failure of insulation between positive and negative terminals of an array or sub-array. The most likely arc to occur is a series arcs because of the large number of series connections in an array and the fact that thermal cycling and aging can lead to poor connections over time. A series arc may be extinguished by shutting down the inverter connected to the array. If the arc is between

positive and negative or is an earth fault on a grounded array then shutting down the inverter may in fact make the arc worse by unloading the array and allowing more current to feed the arc. Under these circumstances the best protection may be an audible alarm or crow-barring of the array. Parallel arcs may be prevented by high quality insulation and good installation practice.

### **Short Circuit Protection**

The type of short circuit protection required in a PV system is dependent on the type of system. Overcurrent protection may be required to protect the PV array wiring, the PV modules and to prevent fires in an installation.

Because a PV array is made up of many sources (ie many PV modules in series/parallel) and may be connected to batteries or other external sources a range of fault situations must be considered in designing cable sizes and overcurrent protection.

Over-current protection is difficult to craft accurately in a PV system so that adequate protection is provided. To provide adequate protection an understanding is required of:

- the source characteristics for a given fault situation
- the chosen protective device characteristics.

Systems can be categorised as:

- limited fault (PV only systems) or
- high fault current systems (Containing batteries or other high current sources).

### **Limited fault current systems**

The current in these systems is limited because of the current limited nature of the PV modules.

In systems with two or less strings over current protection is not required. In systems, with more than two PV strings in parallel, current equal to the (number of PV strings - 1)x  $I_{sc}$  may flow if a fault to earth or a junction box fault occurs in one string. (Refer to Fig. 4.) If the modules and the wiring are not both capable of continuously carrying that level of current then overcurrent protection is required. Generally the most vulnerable piece of equipment is the PV module itself which may be subjected to high reverse currents if a fault in a string occurs. Overcurrent protection is used in individual strings to protect the modules and also to allow the string conductors to be sized according to the overcurrent protection rating.

In these systems crafting the overcurrent protection where it is required can be difficult because there is generally not a large overcurrent available to clear an overcurrent protection device. In Calais et al. (2008) a detailed analysis is provided for selection of over-current protection in this situation of parallel strings in an array.

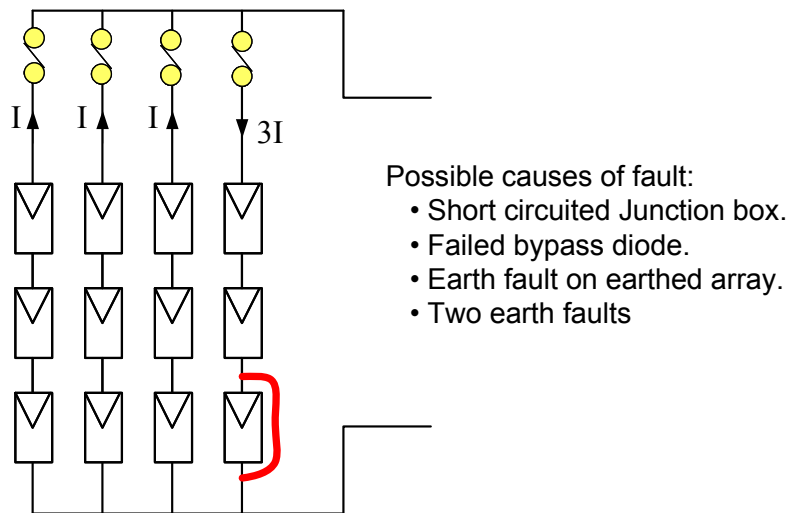

Fig. 4. Reverse current in a faulted string.

### High fault current systems

A high fault current system would be a system which includes batteries or other sources which can supply significant fault currents e.g. a PV stand-alone power system with batteries. In systems with batteries overcurrent protection is generally required and is generally not difficult to craft but large prospective fault currents need to be considered in the design.

### Overcurrent protection

Circuit breakers and fuses are used for overcurrent protection. Each has specific operating characteristics which need to be considered in the design of protection for PV arrays. Of course it is absolutely important that d.c. rated protection equipment only is used in PV array installations and the maximum d.c. voltage of the array must be taken into account in the selection process.

Generally fuses are used for string overcurrent protection because of their availability in high voltage d.c. ratings at reasonable cost. When selecting a fuse it is important to consider not just  $I_n$  nominal rated current of the fuse.  $I_n$  is the current that the fuse can carry continuously without rupturing. It is also important to consider  $I_{nf}$  and  $I_f$ . Where  $I_{nf}$  is the conventional non-fusing current and  $I_f$  is a value of current specified as that which causes operation of the fuse link within a specified time. Note that  $I_f$  is typically 1.6 to 1.9 times  $I_n$ . Note that all these ratings are temperature dependent.

### Low current high voltage modules

A number of manufacturers are now producing low current higher voltage modules. These are typically thin film devices where the module may readily be tailored for a higher effective number of cells. When these modules are incorporated in parallel connected arrays the same issues arise with respect to overcurrent protection but because the reverse current ratings of these modules is small (e.g. 2 Amps or less) the fuse rating needs to be typically at the 1A or less at relatively high d.c. voltage ratings. At present fuses are not available in these ratings and even if they were it is unlikely that they would be robust enough to have long term reliability.

## **Conclusions**

PV arrays are unique electrical systems which require high quality components and careful protection design because they are current limited sources which are often used in series/parallel and they may also involve other sources eg batteries. Fusing of these systems needs to be carefully crafted to achieve desired protection outcomes. Arrays operate in an often hostile outside environment, where deterioration of connections may be a problem. The most serious issue facing the industry at present is the one of series arcs in aging systems. This is something that will probably only be solved by the use of an effective d.c. arc detector which is currently under development. Until this product becomes available it is extremely important that module meeting the most stringent international standards are used in systems where the d.c. voltage is above 120Vd.c., that quality systems are installed by properly trained staff and that systems are maintained regularly to make sure series connections do not deteriorate.

## **REFERENCES**

H. Häberlin, Arc Detector for Remote Detection of Dangerous Arcs on the DC-Side of PV-Plants. International Workshop: Arcing in PV DC-Arrays - Potential Dangers and Possible Solutions, Burgdorf, Switzerland, October 31st 2007.

M. Calais, N. Wilmot, A Ruscoe, O Arteaga, H Sharma, Over-current protection in PV array installations. ISES conference Sydney, 2008.

Spooner, T., Arteaga, O., Calais, M., "Towards a Meaningful Standard for PV Array Installation in Australia", Proceedings of PV in Europe Conf, Rome Oct 2002, pp 887-890 (ISBN 3-936338-13-2)

US – National Electrical Code,(NEC) Article 690 Solar Photovoltaic Systems. USA, 1999

## **BRIEF BIOGRAPHY OF PRESENTER**

Ted Spooner received his BE and ME degrees from the University of New South Wales in 1970 and 1973 and has been a senior lecturer at The University of New South Wales in the School of Electrical Engineering and Telecommunications since 2002. His research interests are in renewable energy applications, energy efficiency and power electronics. He was project leader for Australia's renewable energy systems testing laboratory now known as RESLab. He is currently chair of the Australian Standards Committee responsible for renewable energy systems. He is also the Australian representative on the International Electrotechnical Commission's (IEC) technical committee TC82 for Photovoltaics and co-convenor of the IEC TC82 systems working group developing international standards for photovoltaics.